



# **DIGITAL CINEMA PRODUCTS**

CATALOGUE 2010

powered by

***CHRISTIE***<sup>®</sup>



# Entertainment Solutions

Digital cinema projection

Automation solutions

Auditorium accessories

Projector accessories

Alternative content presentations



**CHRISTIE®**

# The clear choice

## Christie understands the cinema industry

With no margin for error, the show must always go on. Christie brings over 80 years of experience, knowledge and value to your cinema business. We consistently offer you the best. All our cinema solutions feature Academy Award winning DLP Cinema® technology. We pride ourselves on being the first with a 2K solution, the first to offer a 4K ready solution, and the first to introduce TI's new advanced Series 2 DLP Cinema® technology. And we were the first to market a networked on-screen advertising solution to help support and grow your business.

Christie solutions are designed and engineered to provide the lowest cost of ownership in the industry. Our superior projector optics allow us to specify a smaller lamp than any of our competitors and still provide the highest brightness in each class. Within our exceptional line up of products we're confident you'll find a projector that meets your needs.



### DLP Cinema® Technology

2009 Academy Scientific  
and Engineering Award for  
Color Accuracy

A.M.P.A.S.®



# A new world of 2K. The future of 4K.

## Christie Solaria™ Series

---

It's only fitting that as the pioneer of digital projection technology for cinemas, we're the first to offer digital cinema solutions based on Series 2 DLP® technology from Texas Instruments. This technology is designed to be compliant with the Digital Cinema Initiatives (DCI) specification. It offers content owners the highest level of security and exhibitors the easiest solutions to operate and maintain.

We're proud to bring you the new Solaria Series. The Christie Solaria Series integrates the best of our proven CP2000 platform, with further performance enhancements that include standard support for an integrated media block and bandwidth for an ever-increasing variety of content, including 4K. The new Christie Solaria™ Series is the clear choice for any cinema exhibition environment.



Christie's digital cinema projectors are the most deployed in the world. They light up more screens worldwide, with the latest digital and 3D releases, than any other projector provider. Choose the Christie projector that best meets the size of your screen and the requirements of your theater.

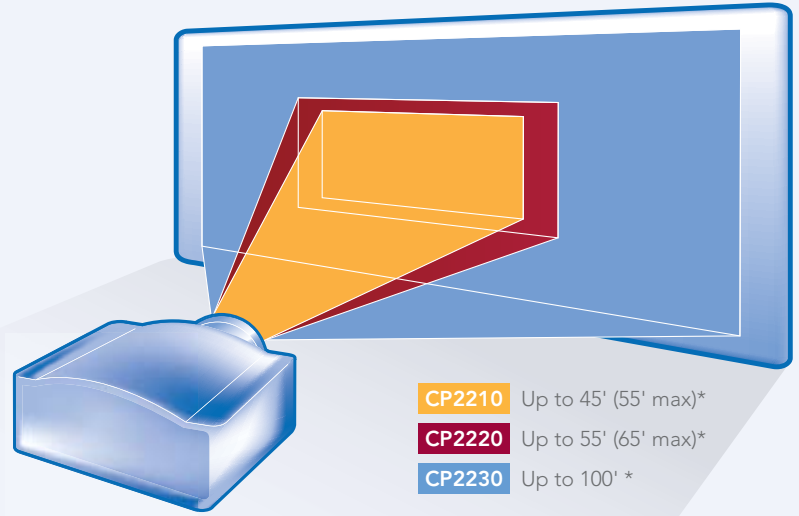

\* Measured at screen center. Depending on auditorium variables such as screen gain, lamp age, geometry, etc.

## The Christie Solaria Series features:

A modular design making it easier for you to swap and access any component you need quickly – we've incorporated quick disconnects and captive screws, included specialized tools, and provided easy access areas to allow swift diagnostic and repair of any major component

Built-in diagnostics on the back of the projector, in the user interface and on the input panels, indicate projector status at-a-glance from anywhere in the projector booth or a remote user interface

The improved Touch Panel Controller is an intuitive and simple to use interface. With new remote diagnostic and operational capabilities, any PC on the network can be used to control any projector either locally or from afar

There are more options to upgrade to 4K DLP® than any other manufacturer because of our knowledge and experience with the 1.2" 2K platform

New electronics and software improve the reliability and uptime of Solaria projectors and the increased processing capabilities allow for faster start-up times

A new level of system integration with options for an integrated media block, streamlined installation support for 3D systems and the fastest, most accurate motorized lens mount in the industry

Additionally, due to the ability to deliver higher brightness with lower power lamps, all current and next generation Christie projectors offer up to 25% lower cost of operation than competing technologies.

The high reliability of our solutions means that in the most critical situations you can depend on Christie to outperform the competition. Our Christie CP2220 projector uses only a 3kW lamp to produce more lumens than our competitors do with a 4kW lamp. As such, it costs you less to power our products and you get better results – which keeps money in your pocket over the long run.

### Additional features

The brightest digital cinema projector in the industry

LiteLOC™ feature for constant image brightness (depending on lamp type, age and screen size)

LampLOC™ feature for motorized three-axis lamp alignment (automatic or manually adjusted)

The products in the Solaria Series offer a wide range of resolution and brightness levels for exhibitors who require projection for the smallest to the largest screens. Included in the series are the Christie CP2210, Christie CP2220 and the Christie CP2230 giving you the ultimate projection solution in terms of reliability, operating costs and upgradability.



With a variety of interface capabilities, including support for HDCP and built-in de-interlacing capabilities, Solaria offers the widest support for a variety of signal formats and connections.



See projector status at-a-glance from anywhere.



Our Touch Panel Controller offers operators an intuitive, simple to use interface.



## Christie CP2210

127-001102-01

The Christie CP2210 is the most compact digital cinema projector in the world and the projector of choice for the world's leading post-production facilities and exhibitors where booth space is at a premium. Coming from a heritage in cinema, we know what it takes to keep production and installation schedules on track. The high reliability of our solutions mean that in the most critical situations, you can depend on Christie to outperform the competition.

Purpose-built for long-term reliability, the Christie CP2210 is the industry's most compact DCI compliant projector available today. At less than 100 pounds, the projector can be transported and installed by only two people.

Based on .98" DLP Cinema® technology, the Christie CP2210 uses high efficiency, long lasting CDXL-SD series Xenon lamps as well as the CXL-14M, a new lamp designed for long life and low power consumption. The competition requires higher wattage lamps for the same light output, giving Christie clear advantage on cost of ownership and lumens per watt.

A robust and reliable addition, the Christie CP2210 features a motorized lensing solution and a selection of eight new zoom lenses to guarantee the right lens solution for virtually any auditorium with absolutely no need for resizing or scaling. It is the projector of choice for small screens and post production applications that demand performance and reliability in a small, affordable package.

HDCP and SNMP support as standard features

One-piece compact design for flexible mounting and installation

Switching 2.1kW lamp power supply for lowest ripple, maximum performance and reliability

Split power operation for use with UPS

Local control via flexible Touch Panel Controller (TPC) and full access from anywhere via web service based GUI

Rear access for quick and easy lamp changes

Brilliant 3D technology for high performance 3D with no need for re-sizing or scaling of feature or alternative 3D content

Optional Christie CP2210 Motorized Auxiliary Lens Mount (MALM) for use with an optional Anamorphic or Wide Converter Lens

New Intelligent Lens System (ILS)™, custom designed for cinema, for reliable motorized lens operation

In it's standard configuration, the Christie CP2210 requires no heat extraction, an optional duct is available if desired

Specifications	CP2210
Brightness* lamp	<ul style="list-style-type: none"> <li>• 1.4kW (CXL-14M) 003-003066-01</li> <li>• 1.8kW (CDXL-18SD) 003-002742-01</li> <li>• 2.0kW (CDXL-20SD) 003-001976-01</li> </ul>
screen size	• <45' (55' max)*
Contrast ratio	• >2000:1 full field on/off
Digital micromirror device	<ul style="list-style-type: none"> <li>• 0.98" 2K 3-chip DMD DLP Cinema®</li> <li>• 2048 x 1080 pixels</li> </ul>
Input line voltage	• Single phase 220V
Number of colors	• 35.2 trillion
Lenses zoom	• See accessory and lens listing page 7-8
optional	<ul style="list-style-type: none"> <li>• 1.25x Anamorphic Lens 38-809054-XX</li> <li>• 1.26x Wide Converter Lens 108-281101-XX</li> <li>• Use of the Anamorphic or Wide Converter Lens requires the CP2210 MALM adapter 119-101101-01</li> </ul>
Power supply	• 1kW-2.1kW low-ripple switch mode lamp power supply
Dimensions size	• Projection head & lamp power supply (LxWxH): 27 x 26 x 15" (687 x 665 x 395mm)
weight	• As installed: 96lb max (43.5kg)

### Top view

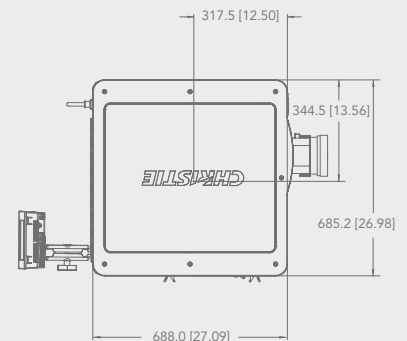

### Side view

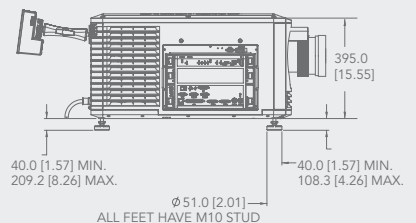

\* Measured at screen center. Depending on auditorium variables such as screen gain, lamp age, geometry, etc.



# Christie CP2220

127-002103-01

Designed for ease of use and maximum reliability with the majority of screens in commercial exhibition, the Christie CP2220 is an all-in-one digital cinema projection solution that is the brightest, highest performance projector with the lowest operating costs in its class. The new user interface and electronics showcase improvements in speed and performance that help make the Christie CP2220 the workhorse of the industry.

Purpose-built for exhibitors, the Christie CP2220 delivers 22,000 lumens with a 3kW lamp in a cost-effective, compact solution for flexible mounting, servicing and installation. The Christie CP2220 is built on proven and reliable 1.2" 2K DMD DLP Cinema® technology, featuring a contrast ratio greater than 2100:1 and reproduces 35.2 trillion colors.

Featuring a internal universal switching lamp power supply, the Christie CP2220 provides maximum performance and reliability. Additionally, the Christie CP2220 is up to 50% smaller by volume than other projectors on the market and can be placed on a variety of rack stands and pedestals. Available as an optional accessory, the motorized lens mount is the fastest and most accurate available on the market. It is compatible with Christie's complete line of zoom lenses.

Based on the popular CP2000-ZX platform, the Christie CP2220 offers full 2K resolution triple flash for 3D projection and built-in support for HDCP and de-interlacing of alternative content. Using the Texas Instruments 1.2" DMD allows for bigger and brighter 3D movies and more efficient cooling which extends the life of the projector.

The ergonomic design offers simplicity of use in a robust and reliable package.

The optional motorized lens mount, designed specifically for use in theatrical exhibition, is stable and solid. With improved airflow and better cooling, the Christie CP2220 promotes longer lamp life, lower cost of ownership and greater reliability than the competition.

One-piece compact design for flexible mounting and installation

Switching lamp power supply for lowest ripple, maximum performance and reliability

HDCP, VNC and SNMP support standard

Touch Panel Controller platform offers operators an intuitive, simple to use interface. With new remote diagnostic and operational capabilities, any PC on the network can be used to control any projector either locally or from afar

Operates with standard 2kW, 3kW and high performance 3kW cinema lamps

UPS split power operation for optimum electrical efficiency

Specifications	CP2220
Brightness* lamp	• CDXL-20 003-000598-XX
	• CDXL-30 003-000599-XX
	• CDXL-30SD 003-001165-XX
nominal	• ~22,000 lumens
screen size	• <55' (65' max)*
Contrast ratio	• >2100:1 full field on/off
Digital micromirror device	• 1.2" 2K 3-chip DMD DLP Cinema®
	• 2048x1080 pixels
	• Upgradable to 1.38" 4K (4096 x 2160 pixels)
Input line voltage	• Single phase 220V
Number of colors	• 35.2 trillion
Lenses zoom	• See accessory and lens listing page 7-8
	optional
	• Wide Converter Lens 108-281101-XX
	• Use of the Anamorphic or Wide Converter Lens requires the MALM 108-111102-XX
Power supply	• 3.3kW low-ripple switch mode lamp power supply
Dimensions size	• Projection head & lamp power supply (approx., LxWxH): 46 x 25 x 19" (1168 x 635 x 483mm)
	weight

### Top view

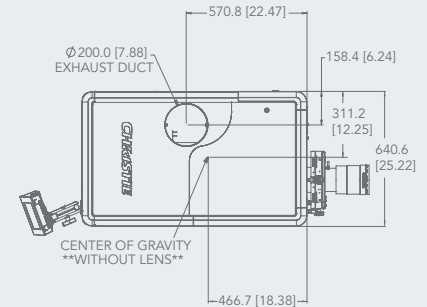

### Side view

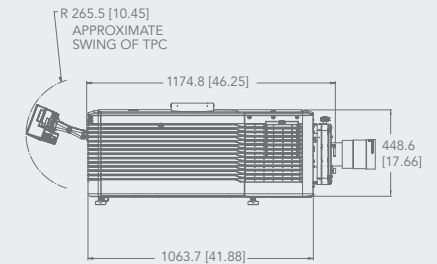

\* Measured at screen center. Depending on auditorium variables such as screen gain, lamp age, geometry, etc.



## Christie CP2230 split-body design

127-003104-01 CP2230 | 127-101103-01 7kW External Lamp Power Supply

The Christie CP2230 offers you the brightest digital cinema projector on the market with its unique optical design. According to Jack Kline, President and COO, the dramatic acceleration in the pace of global installations is a testament to Christie's proven technology, software, and services integrated in each system. "Our unparalleled success is based on more than 80 years of experience. Quality and world-class support services remain our number one priorities as we work with exhibitors to help them make the digital transition seamlessly and revolutionize the movie-going experience."

Setting new standards with Brilliant3D™ 2K technology, the Christie CP2230 features unique optics and superior image processing for crisp, clean images with perfect color saturation and spectacular video. With over 32,000 lumens, the Christie CP2230 is our brightest digital cinema projector for screens nearly 100 feet wide. It is ideally suited for large screen theaters, post-production houses, multi-media theatrical productions and the most demanding 3D installations!

The unique split-body design with separate projection head and lamp power supply lets you put very high power in almost any space. The universal lamp power supply gives you maximum flexibility. Freed from the requirement of a dedicated pedestal, the Christie CP2230 can be installed almost anywhere.

Separate projection head and lamp power supply

Adjustable lamp power – 1000-7000W

>2100:1 sequential contrast ~30,000 lumens

7.5, 15 and 30 meter umbilical lengths for the lamp power supply

Most flexible high power solution in the industry

Highest contrast ratio in 3-chip DLP Cinema®

Lowest cost of operation

Standard support for HDCP, SNMP and VNC

Local control through Christie's industry standard setting Touch Panel Controller

UPS split power operation

Optional motorized lens mount

1-7kW switching power supply

Specifications	CP2230	
Brightness* lamp	<ul style="list-style-type: none"> <li>• CDXL-20 003-000598</li> <li>• CDXL-30 003-000599</li> <li>• CDXL-45 003-000600</li> <li>• CDXL-60 003-000601</li> </ul>	
	nominal	• ~32,000 lumens
	screen size	• >55"*
Contrast ratio	• >2100:1 full field on/off	
Digital micromirror device	<ul style="list-style-type: none"> <li>• 1.2" 2K 3-chip DMD DLP Cinema®</li> <li>• 2048x1080 pixels</li> <li>• Upgradable to 1.38" 4K (4096 x 2160 pixels)</li> </ul>	
Input line voltage	• 3 Phase 208/400V	
Number of colors	• 35.2 trillion	
Lenses zoom	• See accessory and lens listing page 7-8	
	optional	<ul style="list-style-type: none"> <li>• 1.26x Anamorphic Lens 38-809054-XX</li> <li>• Wide Converter Lens 108-281101-XX</li> <li>• Use of the Anamorphic or Wide Converter Lens requires the MALM 108-111102-XX</li> </ul>
Power supply	• 7kW low-ripple switch mode lamp power supply	
Dimensions size	<ul style="list-style-type: none"> <li>• Projection head (approx., LxWxH): 47 x 25 x 19" (1194 x 635 x 483mm)</li> <li>• Lamp power supply (approx., LxWxH): 22 x 16 x 16" (547 x 414 x 407mm)</li> </ul>	
	weight	<ul style="list-style-type: none"> <li>• As installed: 245lb max (111kg)</li> <li>• Lamp power supply: 70lbs max (32kg)</li> </ul>

Top view

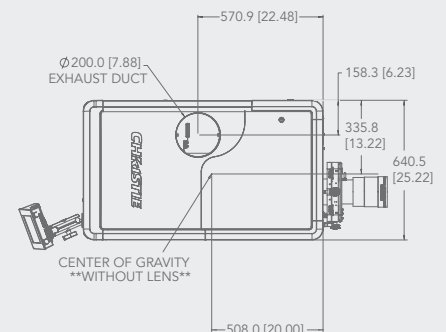

Side view

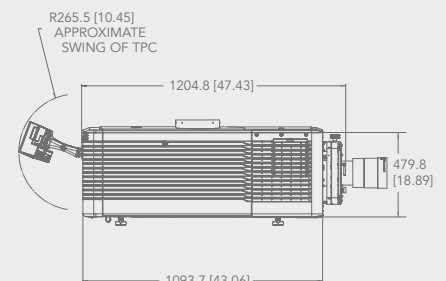

\* Measured at screen center. Depending on auditorium variables such as screen gain, lamp age, geometry, etc.



**Christie ACT**  
108-102101-XX

Now the most popular dedicated digital cinema automation device in the world, the Christie ACT puts control of your single screen, multiplex or entire theater chain in your hands. Our flexible theater automation solution and powerful open architecture can integrate fully with any end user application. With its flexibility, programmability and user-friendly Graphic User Interface (GUI) – the average user can easily customize tasks and events to specifically suit the needs of their own theater operation/complex.

The Christie ACT is a 2RU steel box with general purpose I/O, 2 high current (10A) relays, 10 1A relays, RS-232, RS-422, accessory power, and Ethernet.

The main user interface used for set-up and operation can be accessed from any external computer's web browser.

Completely programmable via easy-to-use web interface

Includes device support for all Solaria Series projectors and various audio processors

Users can define nearly an unlimited amount of "virtual actuators"

Automation via simple GUI or advanced scripting

Sharing scripts between multiple Christie ACTs

Predefined scripts for supporting known devices

Customized support for any product with published interface specifications

**Cine-IPM 2K**  
38-813027-XX

The Christie Cine-IPM 2K is a professional grade scaler for post-production and cinemas the world over, bringing the latest alternative content to the big screen. Using a comprehensive 10-bit image processing package, the Cine-IPM 2K takes control of the incoming signal and will display any standard output format regardless of the source. The Cine-IPM 2K accurately displays non-cinema or alternative content such as broadcast television, satellite, business presentations and HDTV sources. The Christie Cine-IPM 2K offers image scaling, image processing and reformatting. It handles both standard and HD sources and integrates easily for use with any Solaria Series projector. Additional input modules are available to accommodate virtually any digital or analog source.

**Christie Multimedia Adapter**  
111-324201-01, 111-325202-01

The Christie Multimedia Adapter is a video and audio device that can accomplish a unique variety of video scaling and audio conversion tasks. Any item can be scaled and displayed with total end-user control. An on-screen display (OSD) and a front panel LCD with full-featured settings allow you to fine-tune your viewing experience and get the most out of your current AV set-up. The Multimedia Adapter will scale your image to your digital cinema projector or DVI/HDMI display and is HDCP compliant.

**Common accessories**

Part number	Description
38-813028-51	Variable Aperture Kits for 2220 and 2230
700120-074	In-line 120V Duct Fan, 600-CFM
111-277001-01	Three phase to single phase power distribution unit w/accessory power

**Wide Converter Lens (WCL)**  
108-281101-XX

The WCL achieves an accurate unattended zoom from a "flat" image format of 1.85:1 to a "scope" image format of 2.39:1. At the same time, it maintains the full resolution of the source data. Other possible solutions are either impractical, cost-prohibitive or simply do not exist. The WCL simply mounts in front of a standard prime lens and expands the image just like a zoom of 1.26x, expanding the image to effectively decrease the throw ratio. For example, it converts the zoom range of our 2.2-3.0 lens to 1.75-2.38. In essence, the WCL is a focal length adapter.

**Motorized Auxiliary Lens Mount (MALM)**  
119-101101-XX, CP2210  
108-111102-XX, CP2220, CP2230

The MALM moves the WCL out of the light path, so that it does not affect the "flat" image focus, location or performance in any way. Only lenses with throw ratios above 1.45:1 are certified to work with the WCL.

**Rack stand components**

The Christie Rack Stand supports the Christie CP2210, CP2220 and CP2230 projectors. The rack stand is 39.5" high to work with typical port window configurations and can support 36RU of equipment, or 9RU when the Christie CP2230 lamp power supply is mounted inside.

Part number	Description
108-282101-02	Rack Stand (fully assembled)
116-100101-01	CP2220 / 2230 rear feet lock downs
119-100101-01	CP2210 rear feet lock downs



## Motorize-able Lens Mount Motor upgrade for CP2220 and CP2230

Part number	Description
127-102104-01	Kit Motor upgrade

## DLP Cinema® lenses

### High brightness prime lenses (for use in commercial exhibition)

Part number	Description
108-274101-01	1.25-1.45:1
108-342100-01	1.25-1.83:1
108-275101-01	1.45-1.8:1
108-335102-01	1.45-2.05:1
108-336103-01	1.6-2.4:1
108-276101-01	1.8-2.4:1
108-337104-01	1.8-3.0:1
108-338105-01	2.15-3.6:1
108-277101-01	2.2-3.0:1
108-278101-01	3.0-4.3:1
108-279101-01	4.3-6.0:1
108-280101-01	5.5-8.5:1

### High contrast prime lenses (for use in post-production and review rooms)

Part number	Description
38-809079-51	1.25-1.45:1
38-809061-51	1.45-1.8:1
38-809052-51	1.8-2.4:1
38-809053-51	2.2-3.0:1
38-809069-51	3.0-4.3:1
38-809081-51	4.3-6.0:1
38-809080-51	5.5-8.5:1

## Christie CP2210 lenses

Part number	Description
108-319104-01	1.05:1
108-320106-01	1.30-1.75:1
108-327103-XX	1.39-1.9:1
108-329105-XX	1.5-2.2:1
108-321107-01	1.75-2.40:1
108-328104-XX	1.9-3.0:1
108-322108-01	2.40-3.90:1
108-323109-01	3.90-6.52:1

## Digital cinema dimmer

Christie digital cinema dimmers are available in 1, 2, and 4-channel versions for both 110/115 VAC and 220 VAC, 50/60Hz operation. Programming for each of the four presets for intensity levels and fade times are digitally controlled by the input keypad at the dimmer. The front panel has LED indicators (for both power and channel output level) and a manual panic activation/reset button (instant lights/up/full). Optional dimmer mounted circuit breakers are also available. UL and CSA listed.

Extra large heat sink for trouble-free "cool" operation

Easy-to-read display shows light level and up/down fade times

Simple 3-button programming: up/down/set

Channel light level and status indicators

Simple connections and wiring layout

Solid state digital control system, effortless automation interfacing

Part number	Description
700107-019 or 020*	2 x 2400W dimmer
700107-021 or 022*	2 x 2400W dimmer with breakers
700107-023 or 024*	4 x 2400W dimmer
700107-026 or 027*	4 x 2400W dimmer with breakers

\*Note: specify 110 VAC or 220 VAC

## Xenolite® High Performance Lamp Solutions

### Christie Xenolite® lamps

Christie's Xenolite® lamps light up screens around the world and help you provide the best cinema experience to your patrons. To get a true representation of color in any environment requires a truly remarkable light source and the Christie Xenolite® lamp delivers. The lamps offer stable color temperature, a wide range of power levels and excellent color rendition.

### CDXL Xenolite® lamps

At the heart of Christie's digital cinema projector line are Christie's CDXL high performance Xenolite® lamps. These lamps have been optimized for use with Christie digital cinema projectors. With increased brightness in the same form factor as standard cinema grade lamps, CDXL lamps provide higher output and brightness in a more cost-efficient package.

Christie lamps lower operating costs, increase light output and efficiency, and save maintenance costs. With a proven uptime of 99.999% you know your show will always be on screen.

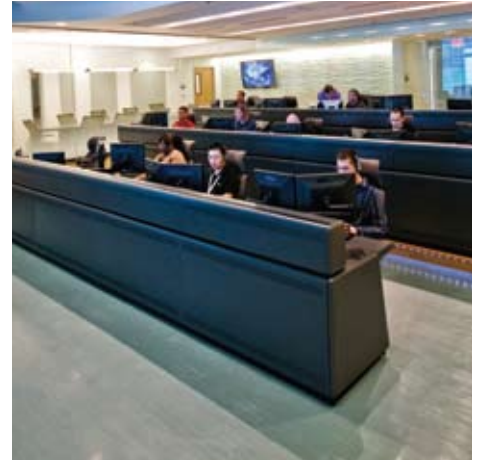

## Christie Managed Services – an extension of your capabilities

National turnkey deployment and support programs

Being successful means focusing on your core competencies. With a broad scale system deployment that is technically complex, the implementation and support may not be your expertise. A partnership with Christie puts the right tools in your hands.

### A partnership of technology, trust and reliability

Large scale national programs, management, procurement, logistics, implementation, monitoring, maintenance

Drawing on over 80 years of experience working with Fortune 1000 companies, Christie Managed Services delivers a portfolio of proven, reliable, services to support our customers' hardware and software assets. As the industry leader in all types of technical service installations, monitoring and maintenance, Christie has the capability to do technology-focused, large scale, national systems.

We've developed a broad range of services that go from inception to sustainment. Christie Managed Services manages programs and provides our customers with a single source contact. We work with our customers on the planning, procurement, logistics, pre-staging and integration and implementation of a rollout. Once your program is up and running, we can monitor and maintain the system – that means reduced downtime and reliable support for our customers. Christie Managed Services delivers reliable technical support to meet the unique technology needs of your organization from round-the-clock, 24/7 programs to Pay-Per-Incident and everything in between.

### Technology-agnostic approach

With a technology-agnostic approach, Christie Managed Services supports a wide array of manufacturers; projectors, technology platforms, visual displays, servers, switchers and networking products.

## 1. Standard terms

1.1 Any offer made by Christie Incorporated ("Seller") to sell goods is subject to these terms and conditions, and, unless otherwise expressly agreed by Seller in writing, any different or additional terms and conditions proposed by the purchaser are hereby objected to and rejected and shall be of no effect.

## 2. Prices, taxes and minimum order

2.1 Unless otherwise specified, prices are FOB point of shipment designated by the Seller. Prices do not include, and the purchaser shall pay (or reimburse Seller for), any and all excise, sales, use, personal property, inventory or similar taxes, charges or levies imposed on or in connection with the sale or use of goods sold by Seller to the purchaser or held by Seller for the purchaser pending shipment.

2.2 Price quotations are subject to change without notice.

## 3. Payment terms

3.1 Unless otherwise specified by Company, payment terms are net thirty (30) days from the date of invoice.

## 4. Deliveries and risk of loss

4.1 In general, minimum of four (4) to six (6) weeks lead time after receipt of purchase order is required, and Seller shall have no liability to Buyer for late deliveries.

4.2 Delivery of goods to the purchaser shall be FOB point of shipment designated by Seller and shall be affected upon delivery to a common carrier for shipment from such location. Upon such delivery, title to and all risk of loss of or damage to the goods shall pass from Seller to the purchaser. Seller shall have no liability or responsibility in connection with claims for loss of or damage to goods incurred after delivery to the carrier, and the purchaser shall pursue all such claims directly with the carrier.

## 5. Changes, cancellation and returns

5.1 Orders accepted by Seller are not subject to change or cancellation by the purchaser unless Seller consents in writing and the purchaser pays to Seller an amount, not to exceed 15% of the purchase price, which covers Seller's losses (including lost profit, if any) and actual costs incurred in connection with such change or cancellation.

5.2 Seller may, but is not obligated to, accept returns of goods. Any such returns (other than returns requested by Seller in connection with warranty claims) will be limited to current goods in original cartons. Any credit issued by Seller will be for the original net purchase price of the goods less any return transportation charge paid by Seller and a restocking charge equal to 20% of the original net purchase price.

5.3 Goods may not be returned to the Seller unless the Seller consents in writing and assigns a return authorization number. Any unauthorized returns or shipping containers received from the purchaser which do not bear a return authorization number will be returned to the purchaser at the purchaser's expense. Return shipments must be prepaid, insured, and shipped at the purchaser's expense.

## 6. Force majeure

6.1 Seller shall have no liability to the purchaser for any delay or failure in carrying out its obligations to the purchaser for reasons beyond the Seller's control, including without limitation, acts of God, war, natural disasters, labor disputes, changes in or compliance with laws, regulations or governmental policies and shortages of supplies and services. Seller may extend delivery until any such cause of delay has been removed, or at its option, cancel the undelivered portion of any order so affected without liability to the purchaser except for the return of any payment made by the purchaser to Seller with respect to any undelivered portion of the order so canceled.

## 7. Warranties and limitation of liability

7.1 Seller warrants to the purchaser that goods sold by the Seller to the purchaser will be free from manufacturing defects in materials and workmanship at the time the first end user purchaser initially installs such goods.

7.2 Except as expressly set forth in Section 7.1 or in writing delivered by company to the purchaser, company makes no warranties to the purchaser, written or oral, express, implied or statutory, in any manner or form whatsoever, including but not limited to any warranties of merchant ability or fitness for any particular use or purpose, which are hereby expressly disclaimed.

7.3 The warranty set forth in Section 7.1 does not apply to goods which have been subject to abuse, misuse, neglect, improper installation or alteration (other than Seller or its authorized representatives) after delivery to the carrier for shipment to the purchaser. Seller makes no warranty as to the useful life of the goods. At Seller's request, the purchaser shall return goods to Seller at its Cypress, California offices for verification that the warranty set forth in Section 7.1 of this Agreement, as limited by this Section 7.3, is applicable. Any such returns are subject to the provisions of Section 5.3.

7.4 In the event Seller determines that the warranty set forth in Section 7.1 as limited by Section 7.3, is applicable to any goods, Seller shall, as the purchaser's sole remedy, replace, or at Seller's sole option, issue to the purchaser a credit for an amount not to exceed the original purchase price paid by the purchaser to Seller for the affected goods. Seller shall have no liability with respect to warranty claims made by the purchaser more than 12 months from

Seller's sale of goods or maximum 24 months from Seller's sale of the goods for SLC Console only. In no event shall Seller be liable to the purchaser for any special, incidental or consequential damages.

## 8. Infringement

8.1 Subject to Section 8.2, Seller shall indemnify and hold the purchaser harmless from any claims that goods sold by the Seller to the purchaser infringe on the patent or other proprietary rights of third parties, except that Seller shall have no liability under this provision unless the purchaser gives to the Seller prompt written notice of any such claim, full authority to settle, compromise or defend any such claim, and full cooperation in connection therewith. In the event the purchaser notifies the Seller of any such infringement claims, Seller shall at its option (a) defend or settle such claims, (b) procure for the purchaser the right to use the goods, (c) substitute non-infringing goods or (d) accept the return of the product and refund the purchase price less appropriate deductions in the event the goods are not returned in the condition in which sold.

8.2 The purchaser shall indemnify and hold Seller harmless from any claims that goods sold by Seller to purchaser in accordance with specifications furnished by purchaser infringe on the patent or other proprietary rights of third parties.

## 9. Designs and trade secrets

9.1 Any drawings, data, designs, or other technical information supplied by Seller to the purchaser in connection with the sale of any goods shall remain Seller's property and shall be held in confidence by the purchaser, and the same shall not be reproduced or disclosed to others without Seller's prior written consent.

## 10. Miscellaneous

10.1 The purchaser's rights; duties and claims under these terms and conditions may not be assigned, transferred or delegated without prior written consent of Seller in each instance.

10.2 These terms and conditions and any contract of sales between the Seller and the purchaser shall be governed by the laws of the State of California.

10.3 If any provision contained in these terms and conditions or any contract of sale between the Seller and the purchaser or any portion of any such provision is held to be unenforceable or invalid, the remaining provisions and portions shall nevertheless be carried into effect.

10.4 The headings contained in these items and conditions are for convenience only and do not in any way interpret, limit or amplify the scope, extent or intent of any of the provisions.

## COMPANY PROFILE



Space Vision was founded in October 2002 by a team of engineers and businessmen with vast experience in the area of electronics and audiovisual systems. The main goal of the company's founders was the creation of a flexible and dynamic enterprise, which would bring a new era in the field of the audiovisual solutions in Greece.

Since its foundation, our company has established a high reputation over the years, by implementing medium and large-scale projects and has managed to hold one of the highest positions in the area of AudioVisual Integrators in the Greek Market.

The company's activities vary from the trade, installation and engineering of audiovisual systems to the implementation of turnkey projects.

Today, the name of Space Vision stands out in hundreds of high-tech installations in cinemas, studios, classrooms, meeting rooms, auditoriums, convention centers, theaters and museums across a broad spectrum of public and private organizations and agencies all over Greece.



### **SPACE VISION S.A.**

312 Mesogeion Avenue,  
153 41 Agia Paraskevi,  
Attika, Greece.

Tel.: +30210282103

Fax: +302825743

E-Mail: [Info@spacevision.gr](mailto:Info@spacevision.gr),

<http://www.spacevision.gr>